

APPLICATION

Side-channel blowers are used in pneumatic transport. Typical applications:

- pneumatic transport,
- graphic machines, pneumatic lifts, multi-stage filtration devices with a very high degree of dust separation,
- industrial vacuum cleaners, pools, aeration in biological sewage treatment plants, electroplating plants, etc.,
- for oil-free transport of non-aggressive and non-explosive gases.

CONSTRUCTION

- side-channel blower with direct drive,
- the impeller is made of aluminum alloy, dynamically balanced according to ISO 1940-1,
- the housing is cast in aluminum alloy,
- blower adapted to work in horizontal or vertical position,
- standard color of the blower is gray RAL 7042,
- maximum temperature of the transported medium is 60°C,
- ambient temperature range from -20°C to +40°C.

MOTOR

- asynchronous single-phase 230V 50Hz (power to 2,2 kW),
- asynchronous, three-phase 230V / 400V 50Hz (power to 3 kW),
- asynchronous, three-phase 400V / 690V 50Hz (power from 4 kW),
- efficiency class IE3 (from 0,75 kW) or IE2 (below 0,75 kW), degree of protection IP55,
- insulation class F,
- three-phase motors are adopted for frequency converter,
- thermal protection (TP or TP and PTC) - in selected motors.

SPECIAL EXECUTIONS

- motor with voltage and frequency of power different than standard,
- single-phase motor adopted to voltage regulation,
- motor with other than standard degree of protection,
- motor equipped with sensors or additional cooling,
- sealing between the housing and the motor,
- maximum temperature of the transported medium above 60°C,
- ambient temperature range below -20°C and above +40°C,
- belt drive.

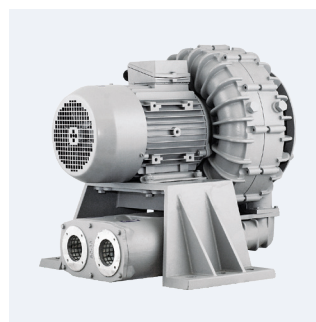

Two-stage version
DSC/PSC



100 Hz motor version
SC-F



Version with belt drive
SC-VB

TECHNICAL CHARACTERISTICS

Type	airflow max	pressure max vacuum pressure		maximum absorbed power	speed	maximum absorbed current	voltage	capacitor	sound pressure level*	weight	article number
	[m³/h]	[mbar]		[kW]	[r.p.m.]	[A]	[V]	[µF]	[dB(A)]	[kg]	
THREE-PHASE											
SC10A 037T	110	126	125	0,37	2800	1,75/1	230Δ/400Y	-	71	15	46511010
SC10A 055T	110	175	185	0,55	2790	2,35/1,35	230Δ/400Y	-	72	16	46511030
SC10C 075T	110	225	270	0,75	2890	2,95/1,7	230Δ/400Y	-	73	18,5	436511050
SC20A 110T	190	202	200	1,1	2890	4,3/2,5	230Δ/400Y	-	75	22	436511070
SC20A 150T	190	202	275	1,5	2880	5,25/3,0	230Δ/400Y	-	75	24,5	436511100
SC20C 110T	190	200	200	1,1	2890	4,3/2,5	230Δ/400Y	-	77	22	436511090
SC20C 150T	190	270	275	1,5	2880	5,25/3,0	230Δ/400Y	-	75	24,5	436511110
SC30A 220T	320	250	250	2,2	2895	7,9/4,6	230Δ/400Y	-	77	36	436511130
SC30A 300T	320	250	300	3	2870	11,0/6,3	230Δ/400Y	-	78	40	436511155
SC30C 220T	320	250	250	2,2	2895	7,9/4,6	230Δ/400Y	-	80	36	436511160
SC30C 300T	320	300	300	3	2870	11,0/6,3	230Δ/400Y	-	78	40	436511170
SC40A 400T	650	210	220	4	2895	7,3/4,2	400Δ/690Y	-	81	67	436511180
SC40A 550T	650	300	300	5,5	2890	9,8/5,7	400Δ/690Y	-	82	70	436511190
SC40A 750T	650	300	395	7,5	2885	14,0/8,1	400Δ/690Y	-	84	73	436511200
SC40C 550T	650	300	300	5,5	2890	9,8/5,7	400Δ/690Y	-	84	70	436511220
SC40C 750T	650	350	395	7,5	2885	14,0/8,1	400Δ/690Y	-	86	73	436511230
SC46A 750T	750	200	200	7,5	2885	14,0/8,1	400Δ/690Y	-	82	105	436511240
SC46A 1100T	750	350	420	11	2900	19,1/11,1	400Δ/690Y	-	84	120	436511242
SC46C 750T	800	200	200	7,5	2885	14,0/8,1	400Δ/690Y	-	84	105	436511244
SC46C 1100T	800	360	420	11	2900	19,1/11,1	400Δ/690Y	-	86	120	436511246
SC50A 750T	1100	175	175	7,5	2885	14,0/8,1	400Δ/690Y	-	82	126	436511250
SC50A 1100T	1100	325	320	11	2900	19,1/11,1	400Δ/690Y	-	84	128	436511260
SC50A 1500T	1100	360	420	15	2940	26,6/15,4	400Δ/690Y	-	88	155	436511270
SC50C 750T	1100	180	175	7,5	2885	14,0/8,1	400Δ/690Y	-	84	126	436511280
SC50C 1100T	1100	325	325	11	2900	19,1/11,1	400Δ/690Y	-	86	128	436511290
SC50C 1500T	1100	375	420	15	2940	26,6/15,4	400Δ/690Y	-	88	155	436511300
SINGLE-PHASE											
SC10A 037S	110	126	125	0,37	2760	3	230	12	70	18	46511020
SC10A 055S	110	175	185	0,55	2780	3,6	230	20	72	19	46511040
SC10C 075S	110	225	270	0,75	2800	5	230	25	73	21,5	46511060
SC20A 110S	190	202	200	1,1	2800	7,2	230	30	75	25	46511080
SC20A 150S	190	202	275	1,5	2740	9,1	230	40	77	26	46511115
SC20C 110S	190	200	200	1,1	2800	7,2	230	30	75	25	46511095
SC20C 150S	190	270	275	1,5	2740	9,1	230	40	77	26	46511120
SC30A 220S	320	250	250	2,2	2800	14	230	-	78	43	46511135

* with silencer

PERFORMANCE CURVES

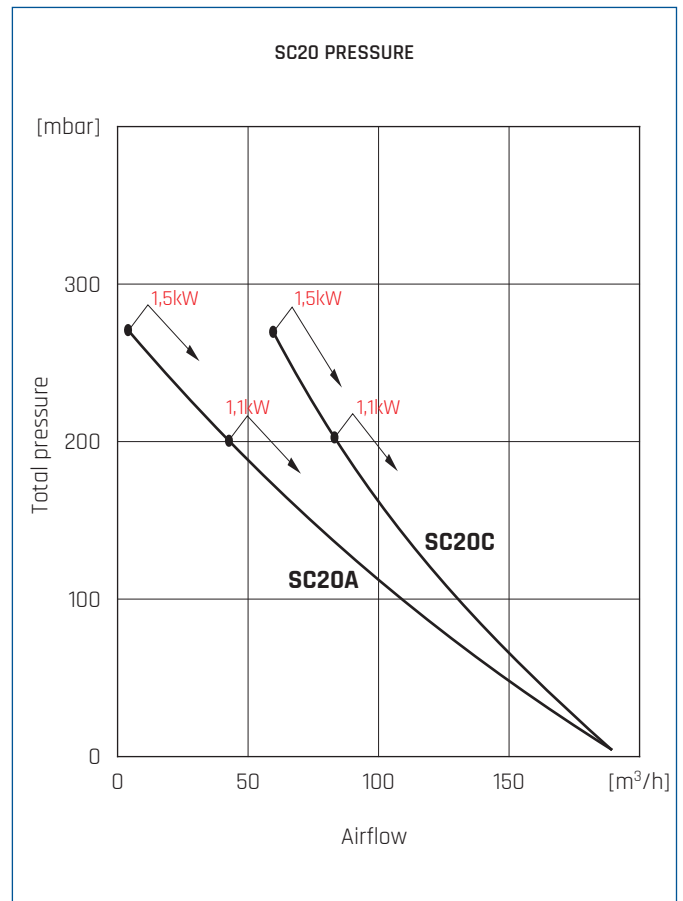
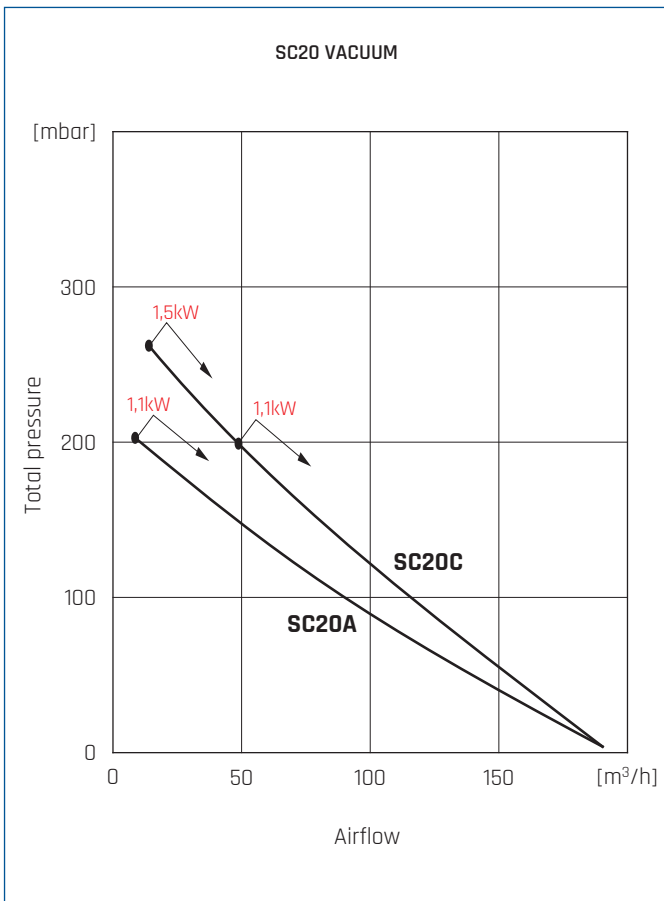
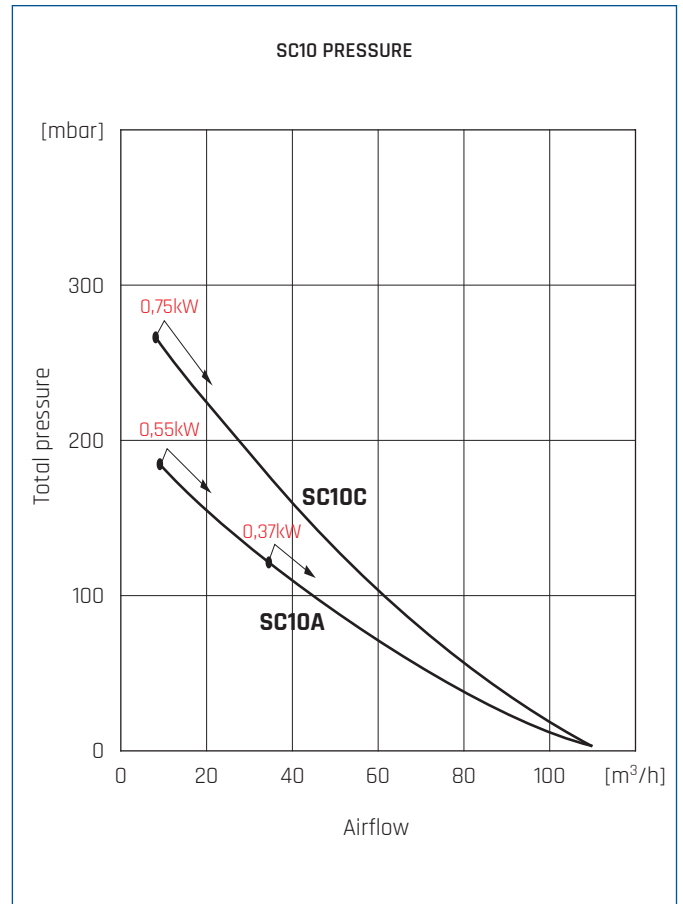
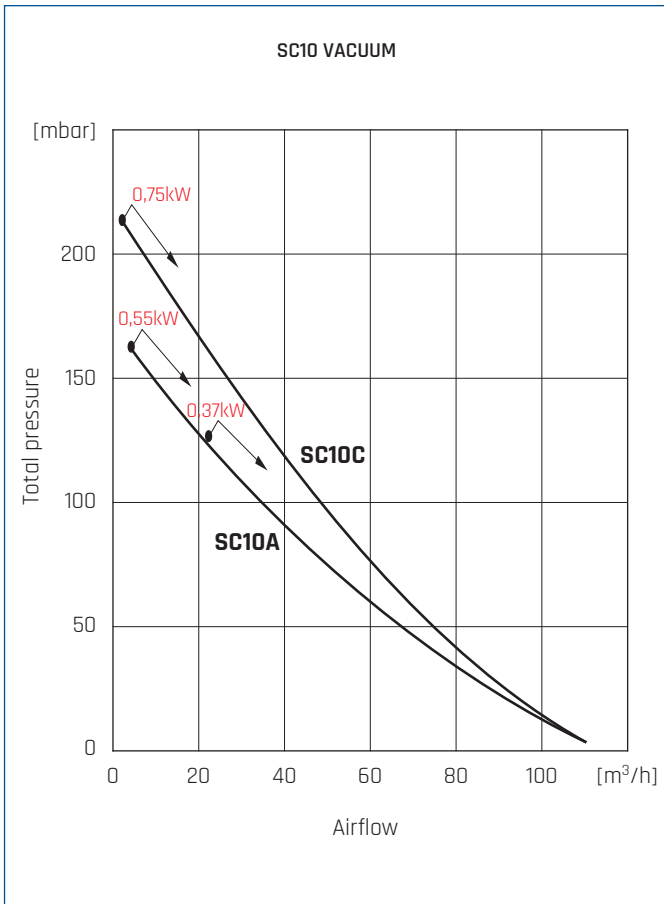

PERFORMANCE CURVES

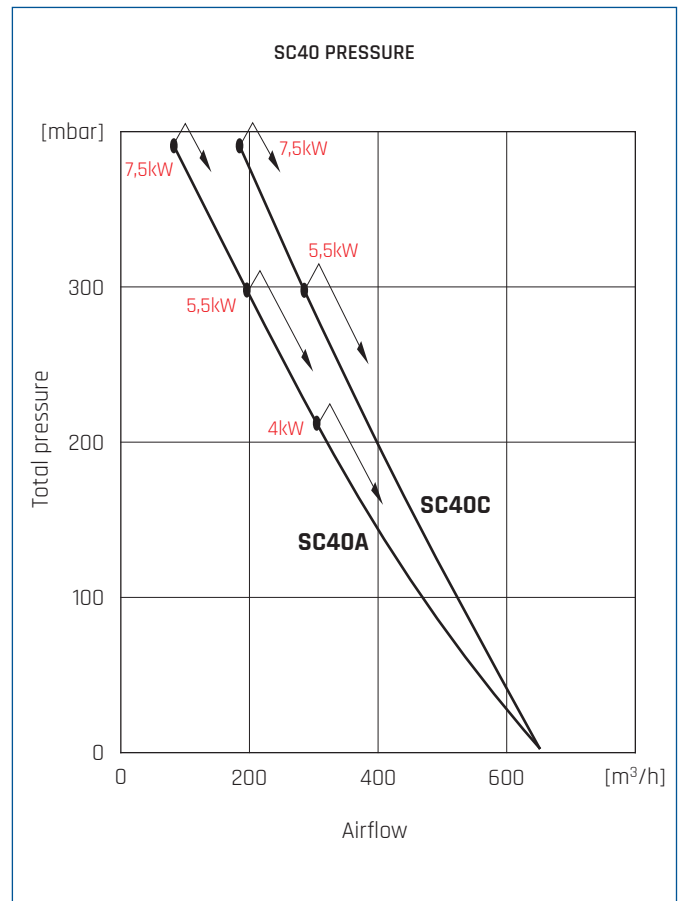
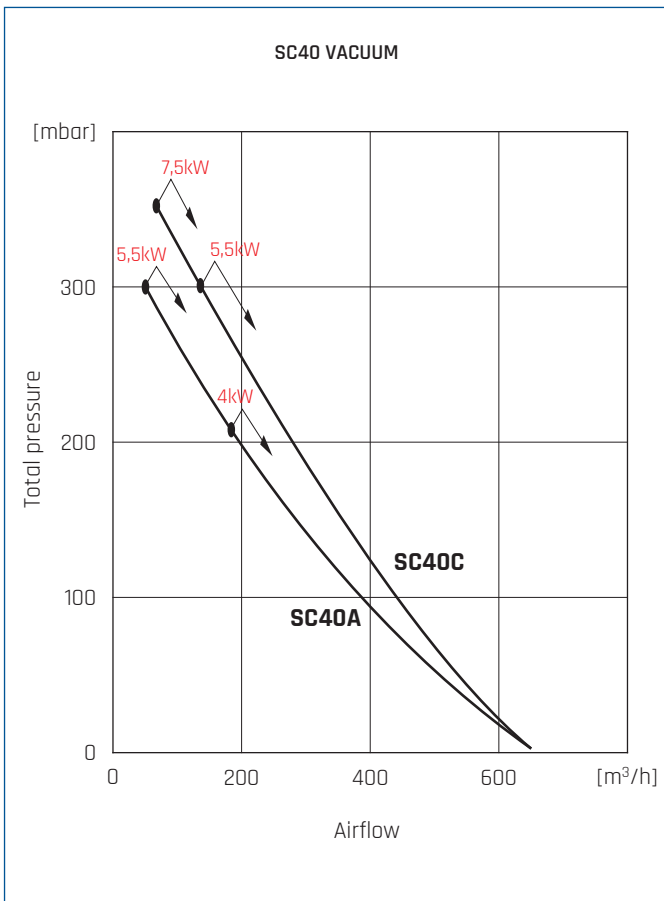
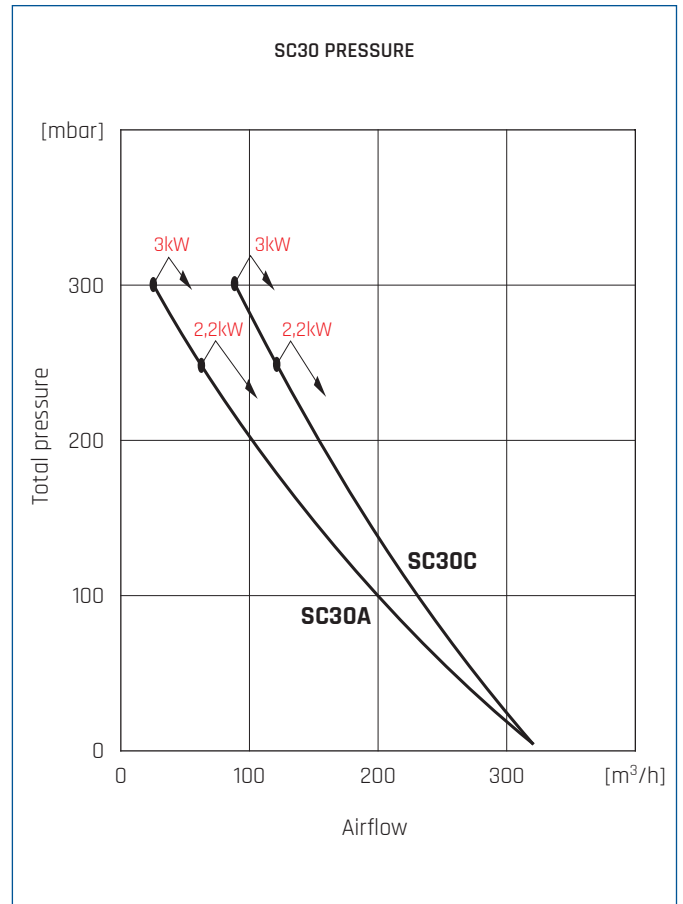
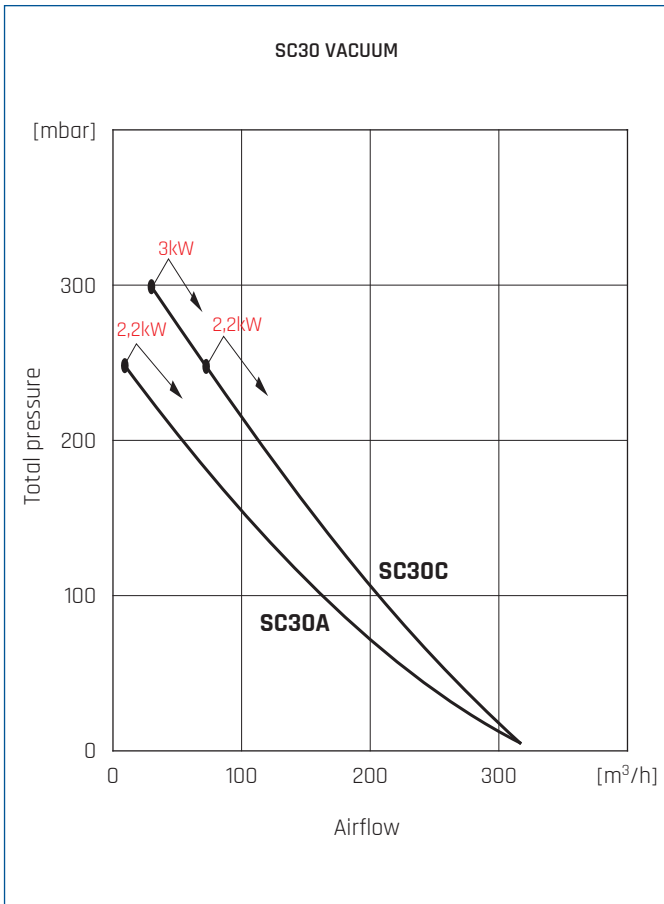

PERFORMANCE CURVES

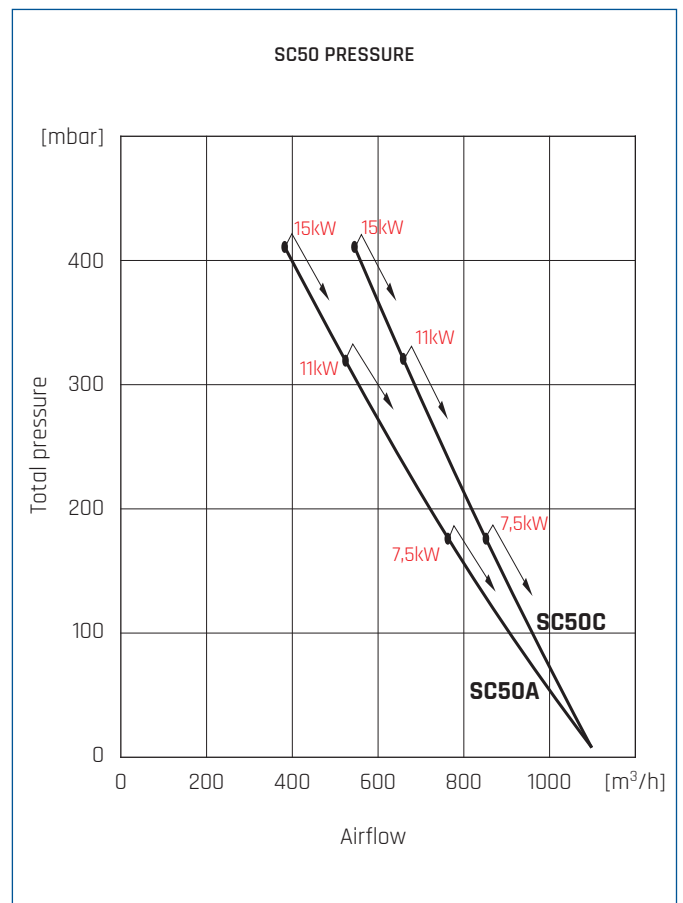
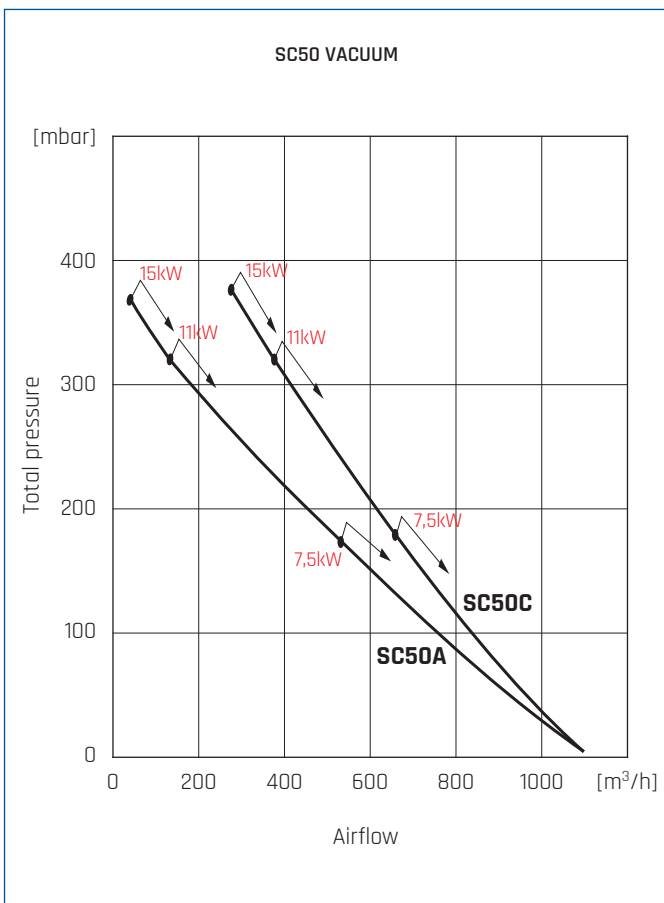
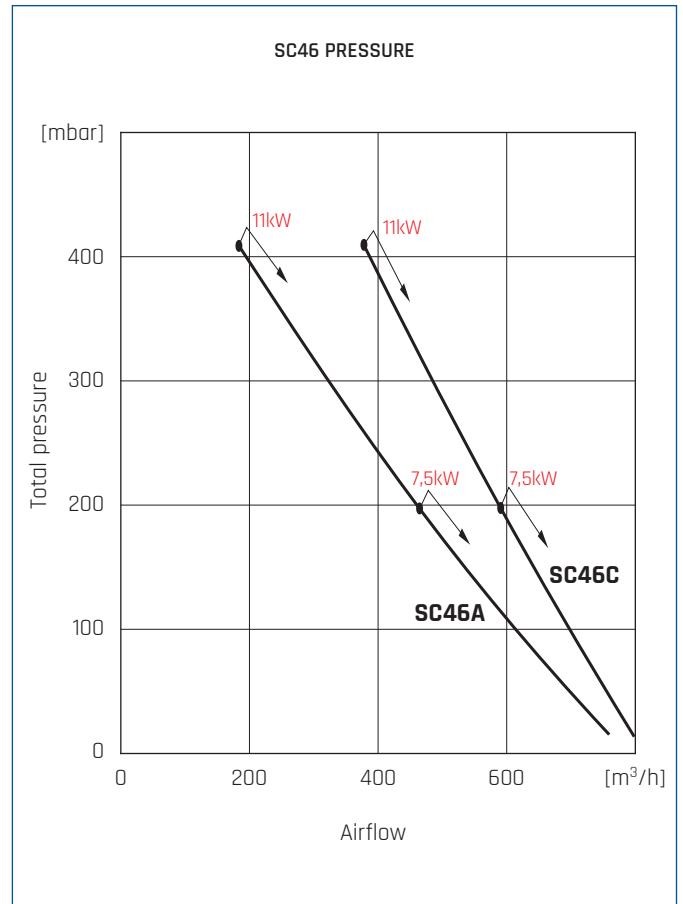
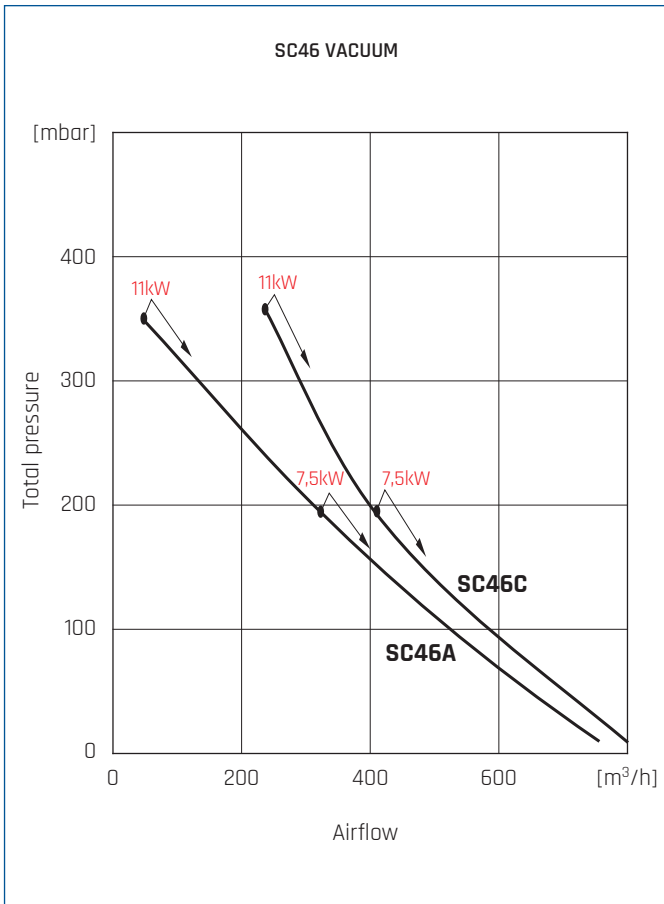

DIMENSIONS [mm]

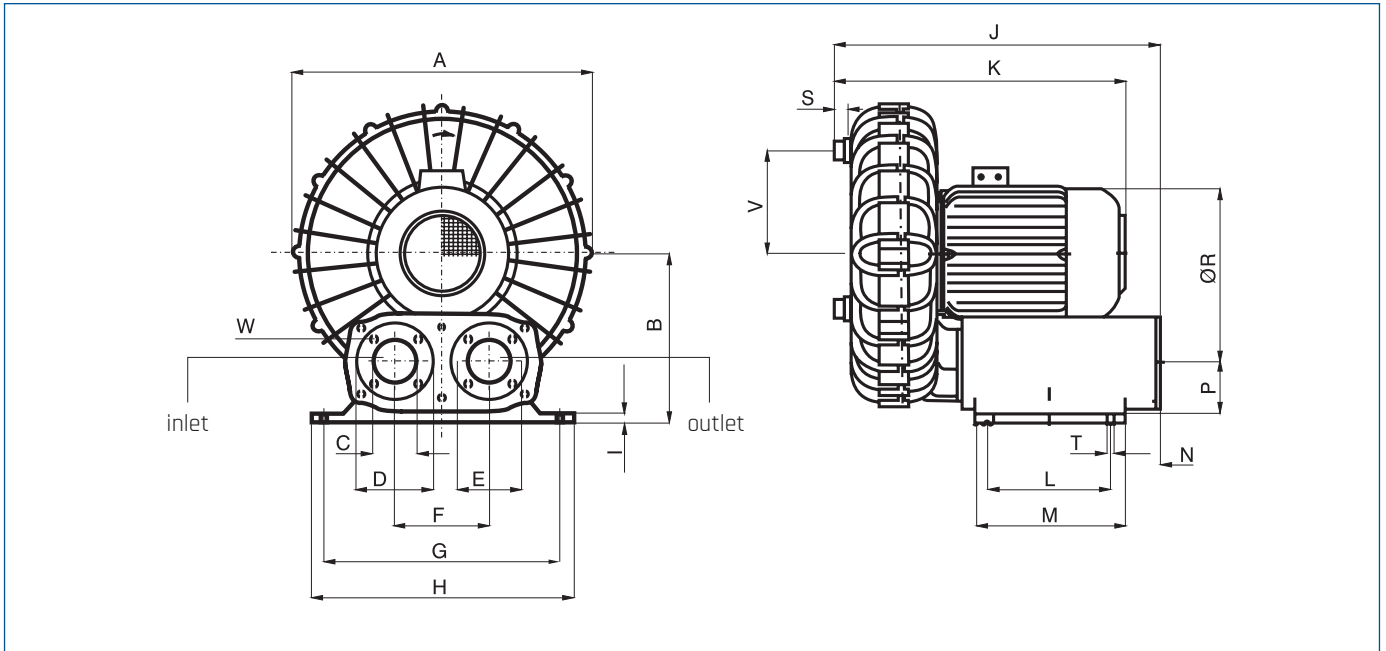

Type	A	B	C	D	E	F	G	H	I	J	K	L	M	N	P	ØR	S	T	W	V
SC10	296	170	45	80	68	90	220	250	12	340	311	120	150	66	60	141	15	11	M5	117
SC20	360	200	45	80	68	90	220	250	12	370	390	120	150	66	60	157	15	11	M5	129,5
SC30	395	225	55	100	85	125	310	350	12	425	410	160	200	72	80	175	20	13	M6	140
SC40	480	275	75	130	110	145	365	420	12	535	520	260	300	34	80	230	30	14	M8	172
SC46	540	303	100	150	130	160	400	450	20	660	600	370	430	50	-	-	30	20	M8	-
SC50	580	336	100	150	130	160	400	450	25	685	650	370	430	50	95	258	30	20	M8	202

ACCESSORY ASSEMBLY

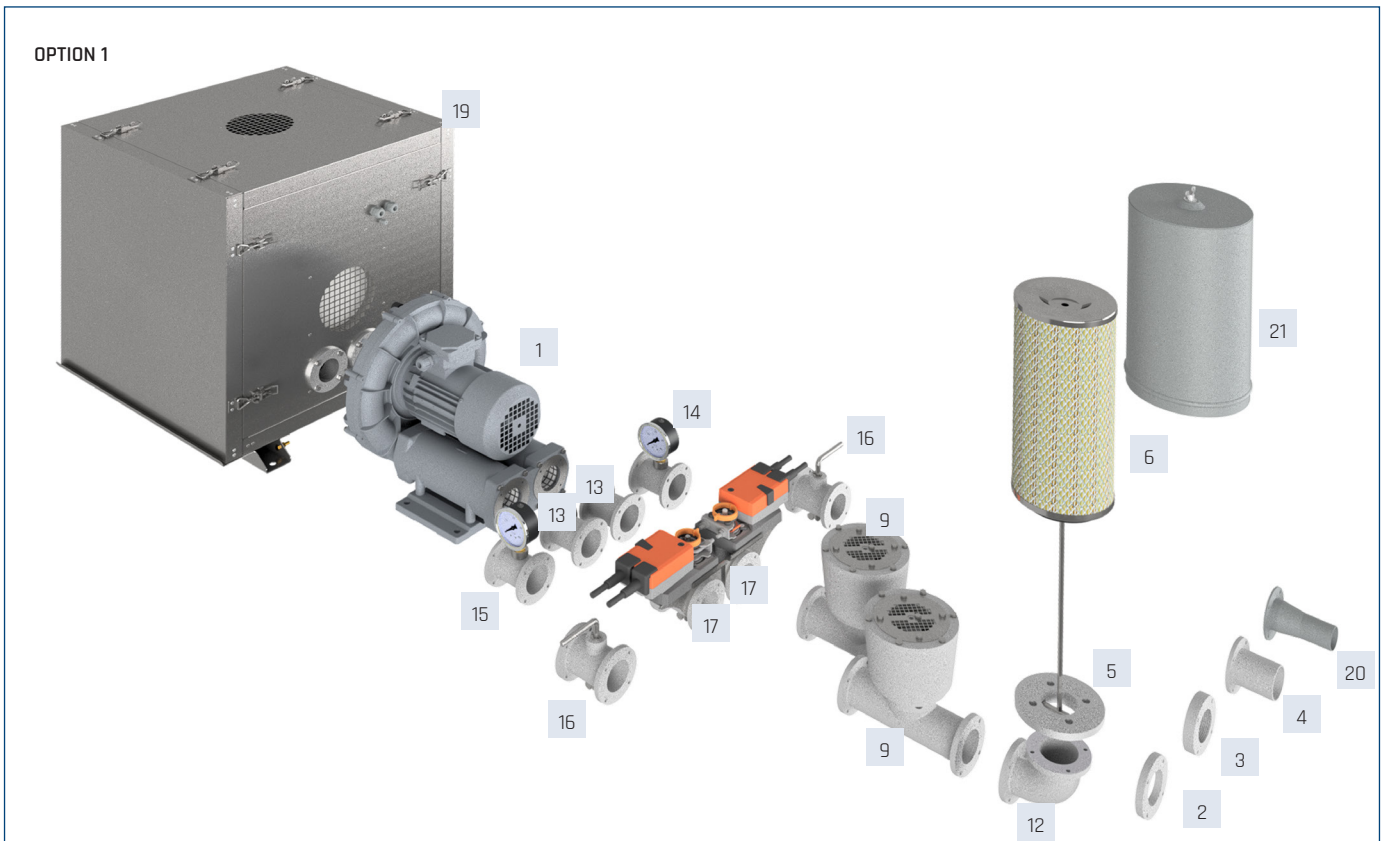

ACCESSORY ASSEMBLY

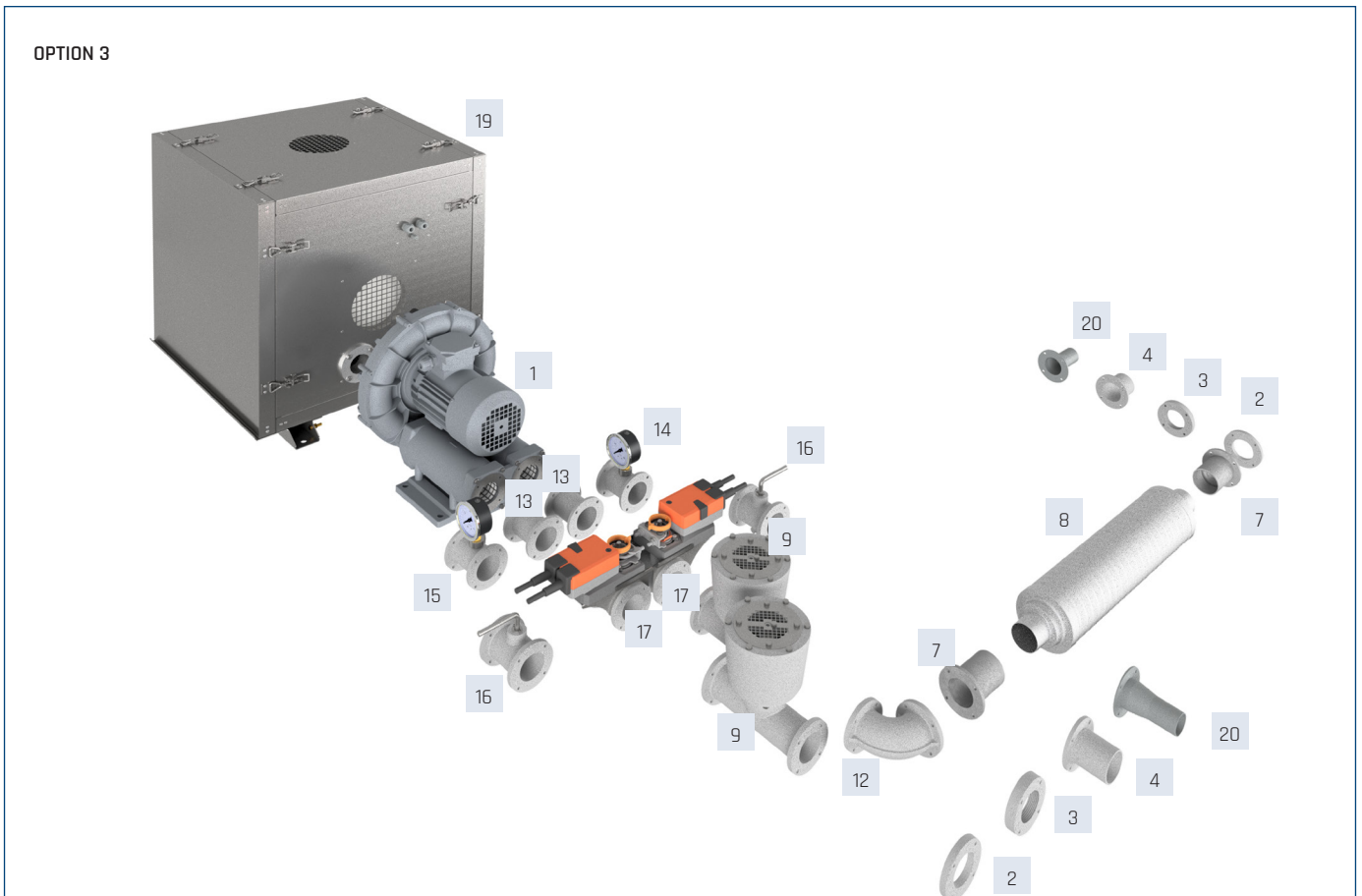
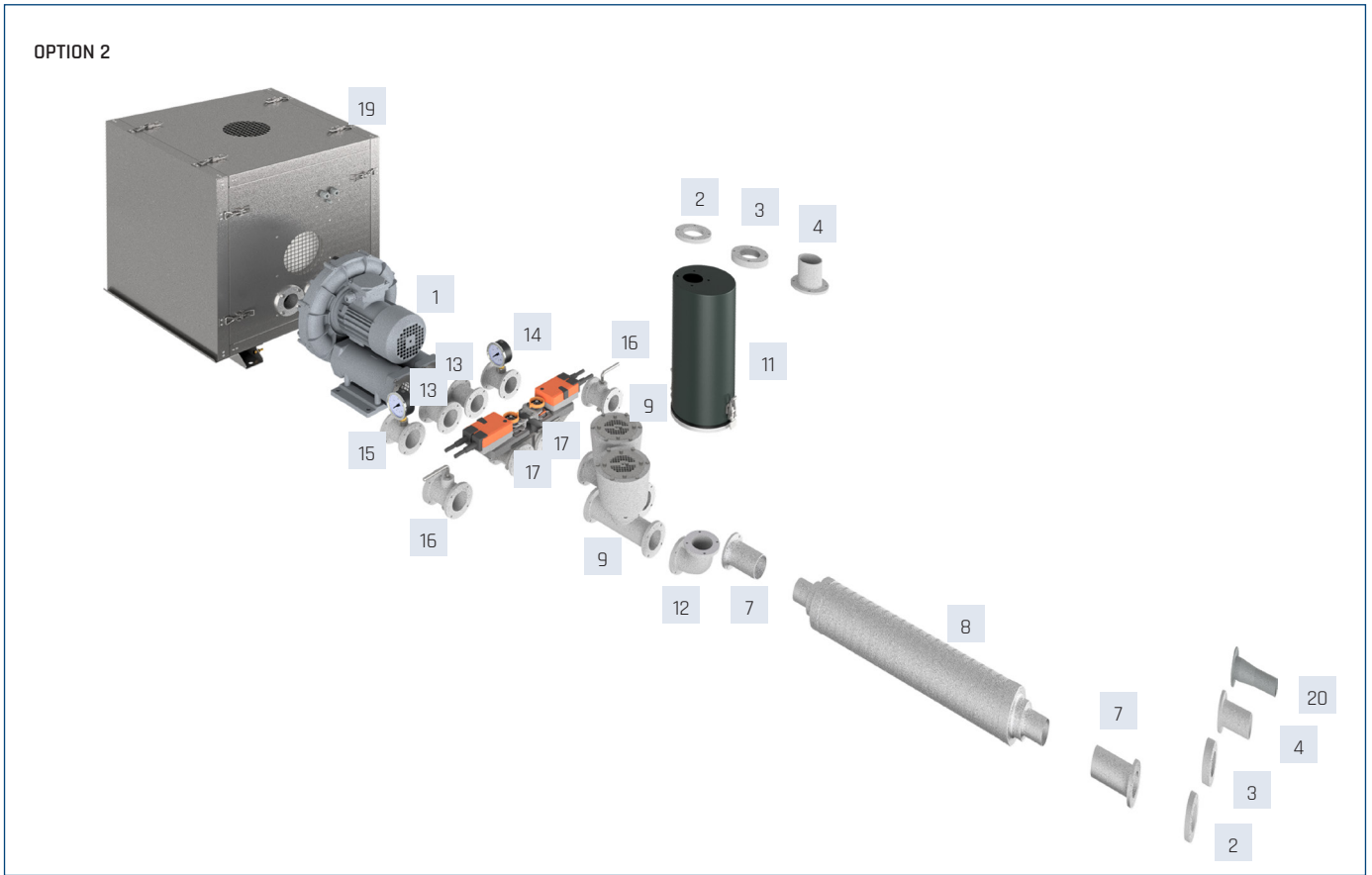

ACCESSORY ASSEMBLY

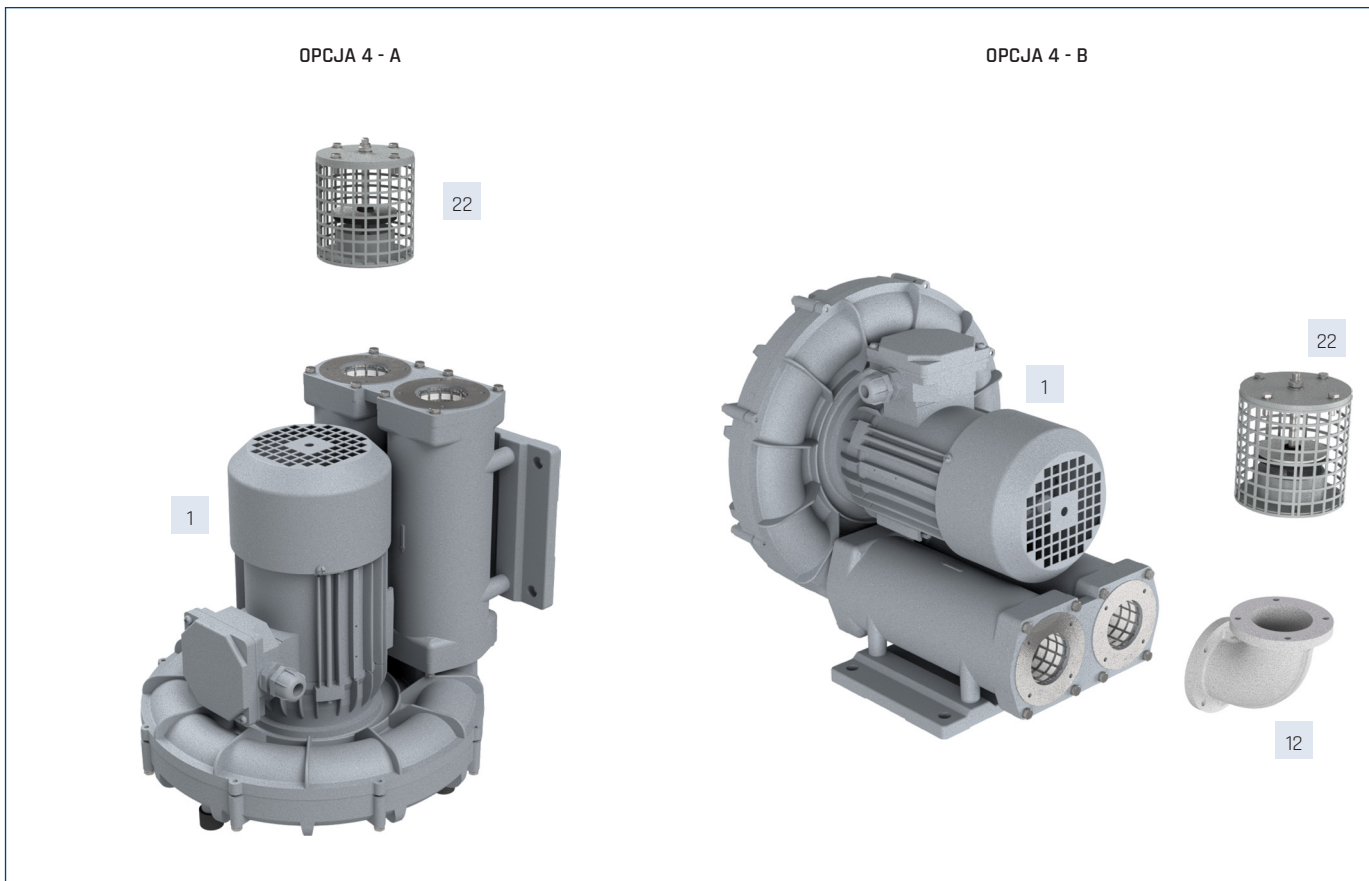

MOUNTING ACCESSORIES

1	2	3	4	5	6	7	8	9	
Type	welding flange	threaded flange	suction connection	filter flange	filter	connection flange	silencer	overload valve PRESSURE	overload valve SUCTION
SC10	45516500	45516600	46515210	46515110	46515039	46515250	46525310	46515520	46515522
SC20	45516500	45516600	46515210	46515110	46515039	46515250	46525310	46515524	46515526
PSC30	45516510	45516610	46515220	46515120	46515039	46515260	46525320	46515530	46515530
SC30	45516510	45516610	46515220	46515120	46515039	46515260	46525320	46515530	46515532
DSC30	45516510	45516610	46515220	46515120	46515039	46515260	46525320	46515534	46515546
PSC40	45516520	45516620	46515230	46515130	46515038	46515270	46525330	46515540	46515540
SC40	45516520	45516620	46515230	46515130	46515038	46515270	46525330	46515540	46515542
DSC40	45516520	45516620	46515230	46515130	46515038	46515270	46525330	46515544	46515546
SC46/SC50	45516530	45516630	46515240	46515140	46515038	46515280	46525340	46515550	46515552

MOUNTING ACCESSORIES

1	11	12	13	14	15	16	17	18	19	20
Type	channel filter	elbow	double flange connection	overpressure manometer	vacuum pressure manometer	manual throttle	automatic throttle	EPDM gasket	sound absorbing housing	reduction
SC10	46515070	25515285	46515160	46515460	46515461	46515162	46515163	91020025-10	70510321	46515290 D=100mm
SC20	46515070	25515285	46515160	46515460	46515461	46515162	46515163	91020025-10	70510321	46515290 D=100mm
SC30	46515075	25515286	46515170	46515470	46515471	46515172	46515173	91020025-11	70510322	46515291 D=130mm
DSC/PSC30	46515075	25515286	46515170	46515470	46515471	46515172	46515173	91020025-11	70510325	46515291 D=130mm
SC40	46515080	25515287	46515180	46515480	46515481	46515182	46515183	91020025-12	70510323	46515292-01 D=60mm 46515292 D=150mm
DSC/PSC40	46515080	25515287	46515180	46515480	46515481	46515182	46515183	91020025-12	70510326	46515292-01 D=60mm 46515292 D=150mm
SC46/SC50	46515085	25515288	46515190	46515490	46515491	46515192	46515193	91020025-13	70510324	46515293-01 D=60mm

1	21	22	23
Type	air filter with cover	flange with valve	duct filter with pollution sensor
SC10	46515151	46515511	46515071
SC20	46515151	46515511	46515071
SC/DSC/PSC30	46515152	46515512	46515076
SC/DSC/PSC40	46515153	46515513	46515081
SC46/SC50	46515154	46515514	46515086

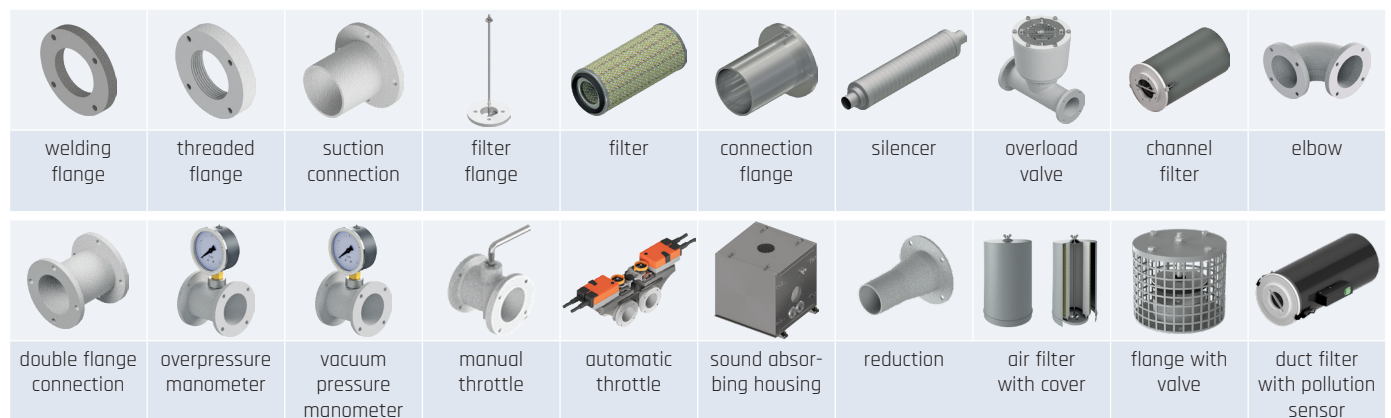

ELECTRICAL ACCESSORIES

Type	inverter	service switch
SC10A 037T	L 0,4kW	R-S 3-F + SP, 10A
SC10A 055T	L 0,75kW	R-S 3-F + SP, 10A
SC10C 075T	L 0,75kW	R-S 3-F + SP, 10A
SC20A 110T	L 1,5kW	R-S 3-F + SP, 10A
SC20A 150T	L 1,5kW	R-S 3-F + SP, 10A
SC20C 110T	L 1,5kW	R-S 3-F + SP, 10A
SC20C 150T	L 1,5kW	R-S 3-F + SP, 10A
SC30A 220T	L 2,2kW	R-S 3-F + SP, 10A
SC30A 300T	L 4,0kW	R-S 3-F + SP, 10A
SC30C 220T	L 2,2kW	R-S 3-F + SP, 10A
SC30C 300T	L 4,0kW	R-S 3-F + SP, 10A
SC40A 400T	L 4,0kW	R-S 3-F + SP, 10A
SC40A 550T	L 5,5kW	R-S 3-F + SP, 10A
SC40A 750T	L 7,5kW	R-S 3-F + SP, 10A
SC40C 550T	L 5,5kW	R-S 3-F + SP, 10A
SC40C 750T	L 7,5kW	R-S 3-F + SP, 10A
SC46A 750T	L 7,5kW	R-S 3-F + SP, 10A
SC46A 1100T	L 11,0kW	R-S 3-F + SP, 16A
SC46C 750T	L 7,5kW	R-S 3-F + SP, 10A
SC46C 1100T	L 11,0kW	R-S 3-F + SP, 16A
SC50A 750T	L 7,5kW	R-S 3-F + SP, 10A
SC50A 1100T	L 11,0kW	R-S 3-F + SP, 16A
SC50A 1500T	L 15,0kW	R-S 3-F + SP, 16A
SC50C 750T	L 7,5kW	R-S 3-F + SP, 10A
SC50C 1100T	L 11,0kW	R-S 3-F + SP, 16A
SC50C 1500T	L 15,0kW	R-S 3-F + SP, 16A

Type	service switch
SC10A 037S	R-S 1-F + SP, 10A
SC10A 055S	R-S 1-F + SP, 10A
SC10C 075S	R-S 1-F + SP, 10A
SC20A 110S	R-S 1-F + SP, 10A
SC20A 150S	R-S 1-F + SP, 10A
SC20C 110S	R-S 1-F + SP, 10A
SC20C 150S	R-S 1-F + SP, 10A
SC30A 220S	R-S 1-F, 10A

Article numbers

L 0,4kW	40016302	L 5,5kW	40016362
L 0,75kW	40016312	L 7,5kW	40016372
L 1,5kW	40016322	R-S 1-F, 10A	91040907
L 11,0kW	40016382	R-S 1-F + SP, 10A	91040907-01
L 15,0kW	40016392	R-S 3-F + SP, 10A	91040908-01
L 2,2kW	40016332	R-S 3-F + SP, 16A	91040908
L 4,0kW	40016352		

